



APEX-CBT

APEX-CBT

A True Revolution In Central Heating
From The Experts In Catalytic Technology!



APEX-CBT

The First

Blaze King's new APEX-CBT, Catalytic indoor furnace is the first furnace to meet and exceed testing requirements of the rigid B415. test standard. The B415 test standard measures both overall efficiency as well as emissions. You'll be impressed with the test results:

Btu Output-High	47,996
Btu Output-Low	13,779
Emissions gr/hr	3.3

Actual Btu Output can be increased up to 80,000 Btu's based on wood size, species of wood, moisture content, times between re-loading, and draft. Blaze King recommends a flue draft of .05" of water column.

Overall efficiency is based upon burning your stove on low, medium low, medium high and high burn rates. Low Heat Value (LHV) is the European method of testing efficiency and excludes any Btu's consumed in an effort to extract all the moisture from the wood fuel. Blaze King prefers the overall efficiency given it best reflects real world performance.

Overall Efficiency	87.2%
Low Heat Value (LHV) Efficiency	90.7%

The Best

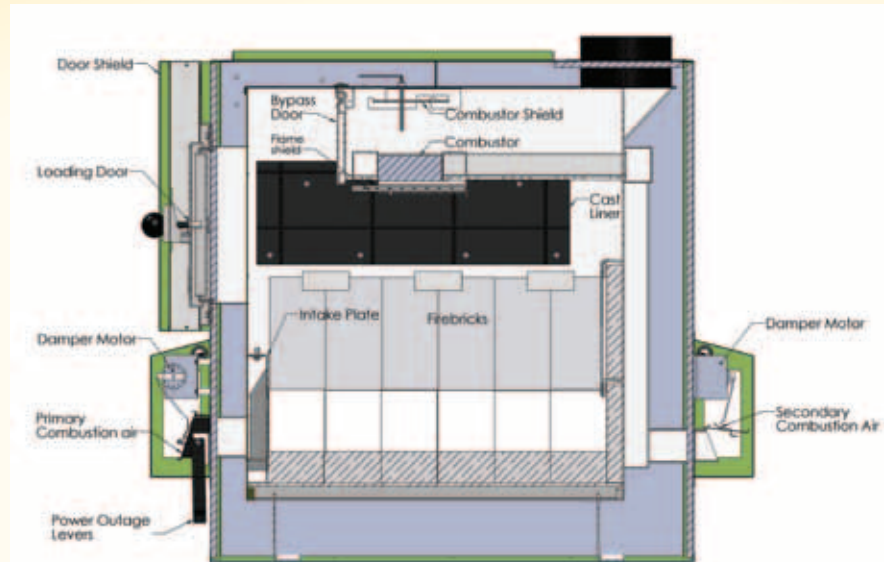
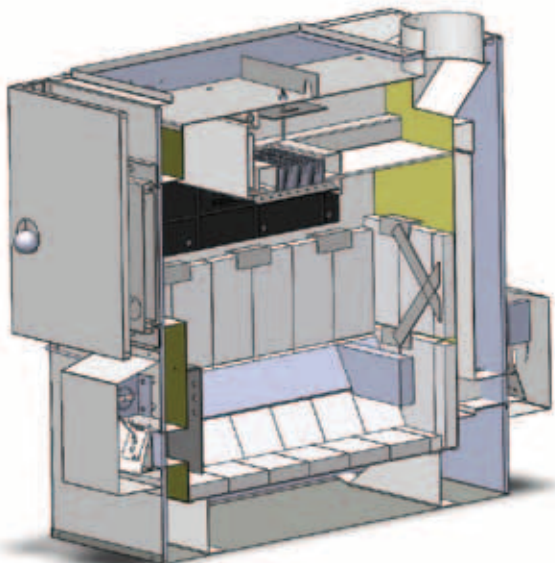

Features include:

- **Accepts Large 26" Logs or Fuel Length**
- **Use As Stand Alone Furnace or in Combination With an Existing Furnace**
- **Long Overnight Burns With Large 5.7 Cubic Foot Firebox**
- **Catalytic Post Burn With Preheated Secondary Air**
- **12 Gauge Firebox With Cast Liner and Thermal Firebrick**
- **20 Gauge Insulated Cabinet**
- **Wall Mounted Thermostat**
- **Optional VB 1000 Blower**

Possible Configurations

There is great flexibility in your choice to help save our environment. You can use the APEX-CBT as a stand-alone renewable fuel furnace to heat your home or reduce your monthly heating bill by using it in combination with your existing furnace system. As a stand-alone furnace, you'll need the Blaze King VB1000 blower. However, if you use the APEX-CBT in combination with your existing system, you'll take advantage of your already present furnace and blower. Here are just a few possible configurations:

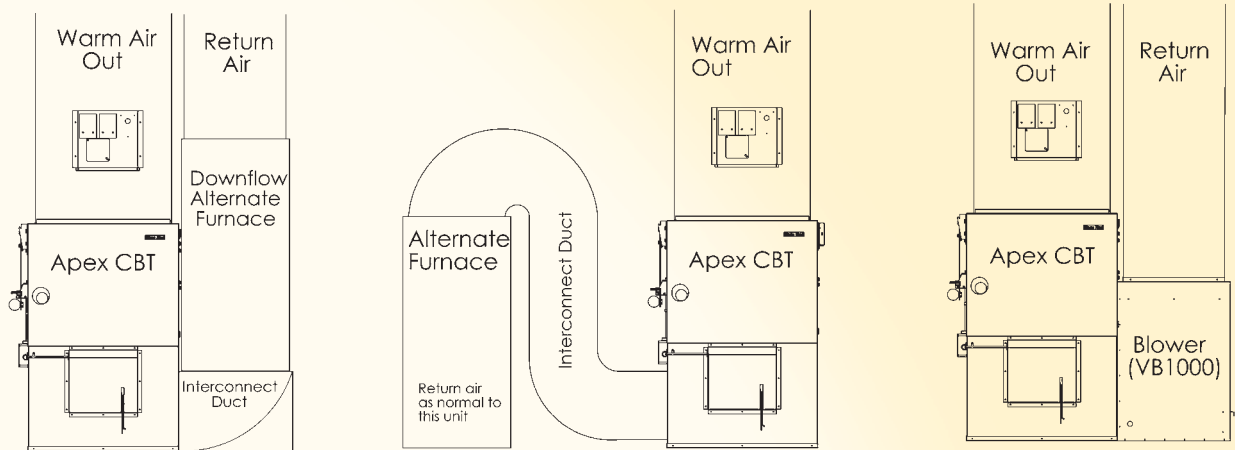

The APEX-CBT Output Plenum Size measures a large 25.75" x 24", accommodating all the hot air needed to keep you comfortable in your home. You cannot however install the APEX-CBT to where the warm air outlet operates below the height of the APEX-CBT furnace cabinet.

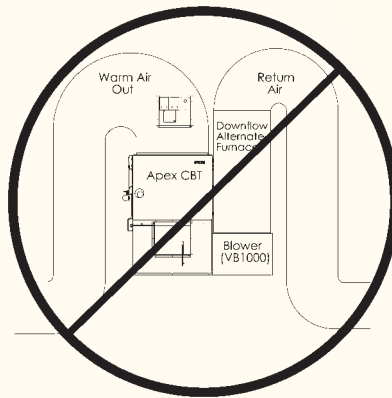

In Combination Maximum Btu's

When used in combination with your existing furnace please note the restrictions below.

Gas	120,000 Btu
Electric	30 KW
Oil	.81-1.2 gallon per/hour

You'll Need a Blower

When you purchase your APEX-CBT you'll need a blower system to move the air. In fact, a blower is required. The Blaze King VB1000 is a variable speed 900-1200 CFM blower. It comes with a 24" x 20" air filter. The 1/3rd horsepower, 110V motor operates inside a 20 gauge baked enamel solidly constructed cabinet. To allow for increase airflow, the inlet duct size measures 22" x 17 5/16".

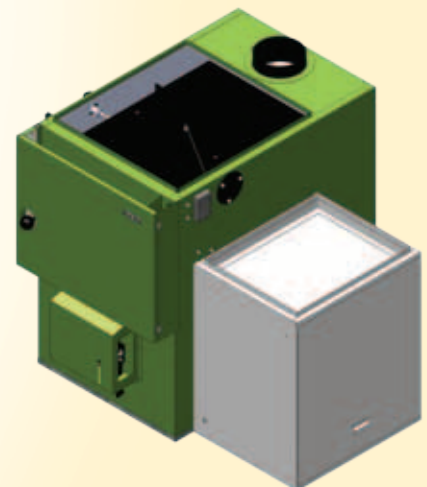

APEX-CBT

Clearances and Specifications

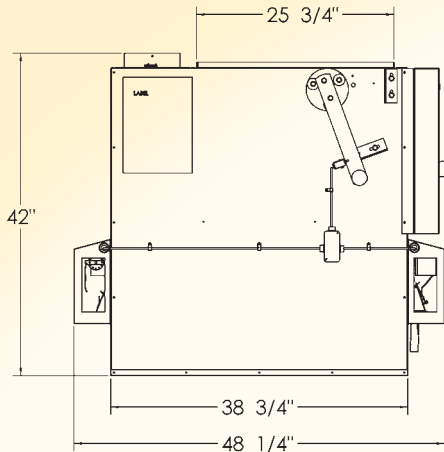

Unit Dimensions

Height	40"/1016mm
Width	26.5"/673mm
Length	48"/1219mm
Fire Door Opening	12" x 13"
	304mm x 330mm
Firebox Length	27"/686mm
Width	16"/406mm
Height	24"/610mm
Capacity	5.7 Cu. Ft.
Fuel Length	26"/660mm
Weight	550lbs./253kg
Flue Collar I.D.	7"

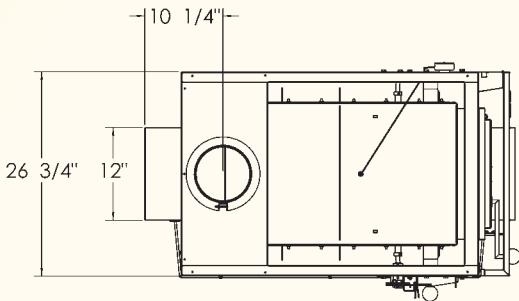
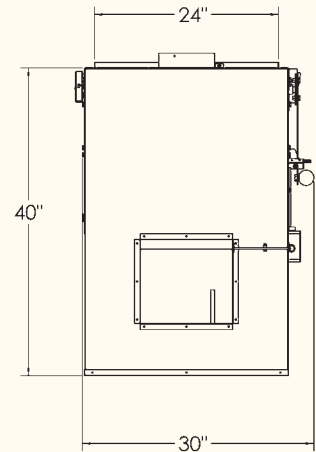

Floor Protection

When installed on a combustible floor, floor protection of a non-combustible shield is required underneath unit protruding 8" to each side and 18" in front of loading door measuring: 66" x 42.5"/1676mm x 1080mm.

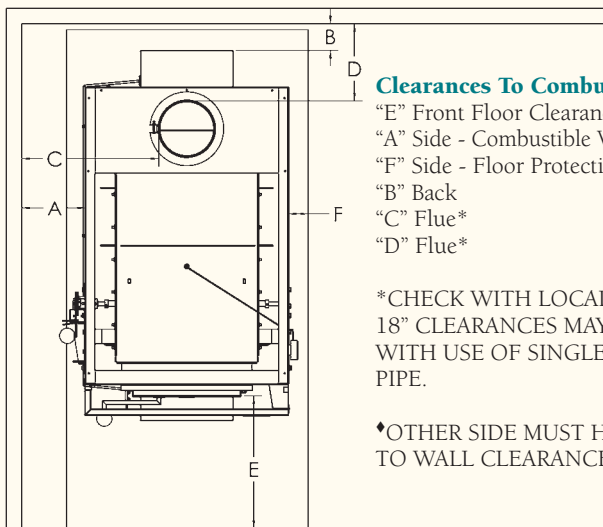
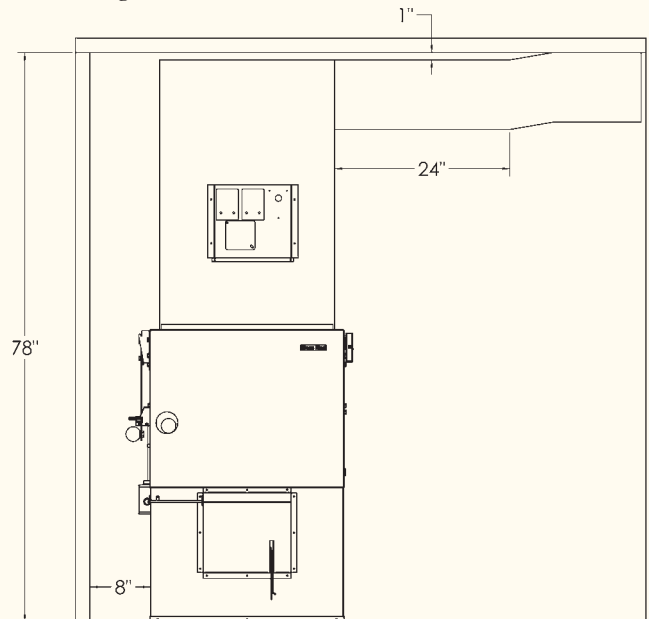

Clearances To Combustibles

"E" Front Floor Clearance	18"/457mm
"A" Side - Combustible Wall♦	6"/150mm
"F" Side - Floor Protection	8"/203mm
"B" Back	3.5"/90mm
"C" Flue*	16"/410mm
"D" Flue*	10"/254mm

*CHECK WITH LOCAL CODES.
18" CLEARANCES MAY BE REQUIRED WITH USE OF SINGLE WALL STOVE PIPE.

♦OTHER SIDE MUST HAVE 18"/457mm TO WALL CLEARANCE

NOTICE: Improper installation of your wood burning appliance or failure to operate it according to the guidelines detailed in the owners manual, may negate your warranty and endanger your home or family. Contact local building or fire officials about restrictions and installation requirements in your area. Photos and illustrations are for descriptive purposes only. Changes dictated by the manufacturer's continuing design improvement programs may not be shown. These products are covered by one or more patents in the United States, Canada and other countries. All Blaze King® Industries products are manufactured under license agreement from: Blaze King® Industries, 146 A Street, Walla Walla, WA. 99362 and in Canada by Blaze King® Systems Inc. 1290 Commercial Way, Penticton BC V2A3H5. Design and specifications subject to change without notice. 01/11 CP78135 5M

Your Authorized Dealer:



Blaze King® Industries
www.blazeking.com